



INSTALLATION INSTRUCTIONS

Read installation instructions in its entirety before installing your Coil-Rite Kit

WARNING

Do not inflate this assembly when it is unrestricted. The assembly must be restricted by a coil spring. Do not ever inflate beyond recommended operating pressures for your specific vehicle. Improper use or over inflation may cause property damage or severe personal injury.

Firestone Industrial Products
Carmel, Indiana, USA

NOTE 1:

If your vehicle is equipped with vibration dampers between the turns of the coil, it is necessary that these be removed before installing the air springs.

STEP 1 - VEHICLE PREPARATION

Remove the positive battery cable. With the vehicle on a solid level surface chock the front wheels. Raise the rear wheels of the vehicle using a lift or platform jack rated for your vehicle weight. Remove the rear wheels. Lower the vehicle onto jack stands rated for your vehicles weight making sure the suspension is fully extended. (Do NOT use wood or concrete blocks to support the weight of the vehicle.)

STEP 2 - SHOCK ABSORBERS

If necessary, additional clearance between the coil spring turns may be obtained by removing the shock absorbers from the lower mounts and lowering the suspension an additional one to two inches. (CAUTION: Do not put strain or tension on the flexible brake line.)

STEP 3 - AIR SPRING PREPARATION

Cut a section of air line tubing 3 inches in length and install into the push-to-connect fitting on the air spring. Exhaust the air from the air spring by rolling it up toward the air inlet. After the air has been exhausted, install the plug into the tubing coming out of the air spring see Figure "A".

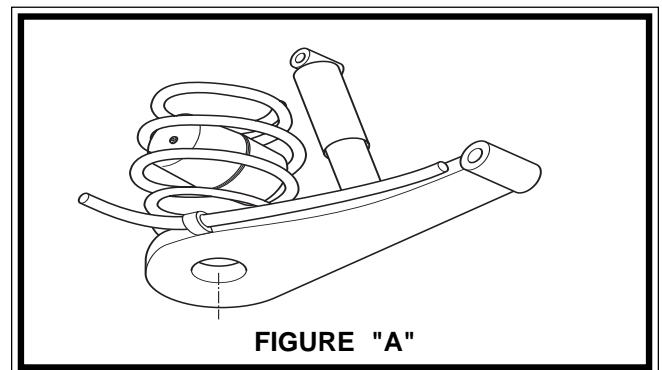

FIGURE "A"

PARTS LIST

DESCRIPTION	QTY.
AIR SPRINGS	2
LOWER SUPPORTS	2
18' AIR LINE	1
NYLON TIE	6
PUSH-TO-CONNECT INFLATION VALVE	2
5/16" FLAT WASHER	4

RECOMMENDED OPERATING PRESSURES

Passenger Cars	5 - 35 p.s.i.
----------------	---------------

COIL-RITE INSTALLATION PROCEDURE

STEP 4A - INSTALL THE AIR SPRING

(General Motors vehicles, Taurus and Sable station wagons)

Insert the top of the flattened air spring into the coil spring through the middle of the coil spring with the push to connect air inlet at the middle of the spring pointing to the center of the vehicle *see Figure "B"*.

STEP 4B - INSTALL THE AIR SPRING

(Chrysler, Dodge, Plymouth vehicles, Ford Thunderbird and Mercury Cougar)

NOTE: Do not remove the coil spring on the Thunderbird or Cougar

The vehicles in this section do not have a hole in the lower spring seat. Mark the hole to be drilled with a center punch in the center of the lower spring seat. Drill a 3/8" hole in the center of the lower spring seat *see Figure "C"*.

The jounce bumper within the coil spring will have to be trimmed to accommodate the air spring. Mark the jounce bumper 1/2" down from the top of the metal retainer. Cut the jounce bumper at this mark and smooth the edges with a file *see Figure "D"*.

Insert the top of the flattened air spring into the coil spring through the lowest opening in the coil spring with the push-to-connect air inlet at the bottom of the coil spring *see Figures "E" & "F"*.

STEP 4C - INSTALL THE AIR SPRING

(Eagle Summit station wagon and Mitusubishi Expo)

NOTE: Your vehicle may not have a hole in the lower spring seat to allow the air line to pass through. If no hole exists, follow "*Prepare the vehicle for installation.*" If your vehicle does have a clearance hole, proceed to "*Installing the air spring.*"

PREPARE THE VEHICLE FOR INSTALLATION

Mark the hole to be drilled with a center punch in the center of the lower spring seat. Drill a 3/8" hole in the center of the lower spring seat *see Figure "C"*.

INSTALLING THE AIR SPRING

Insert the top of the flattened air spring into the coil spring through the lowest opening in the coil spring with the push-to-connect air inlet at the bottom of the coil spring *see Figures "E" & "F"*.

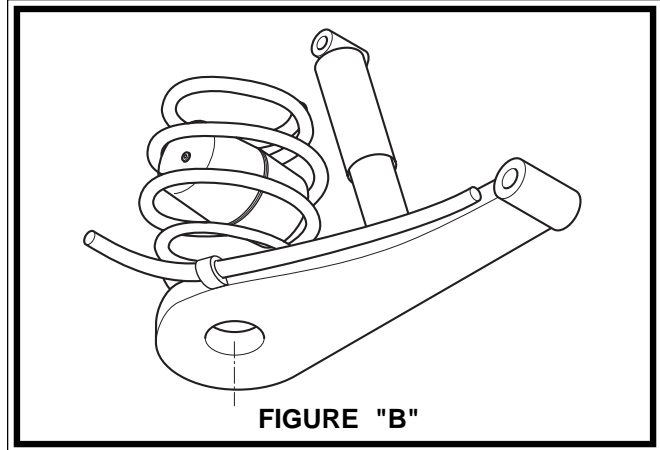

FIGURE "B"

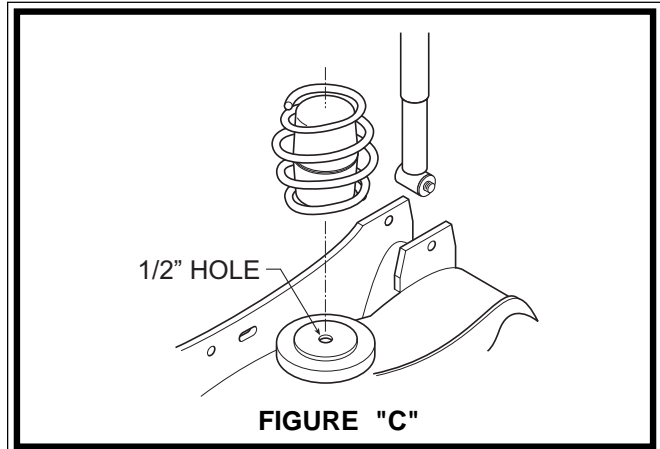
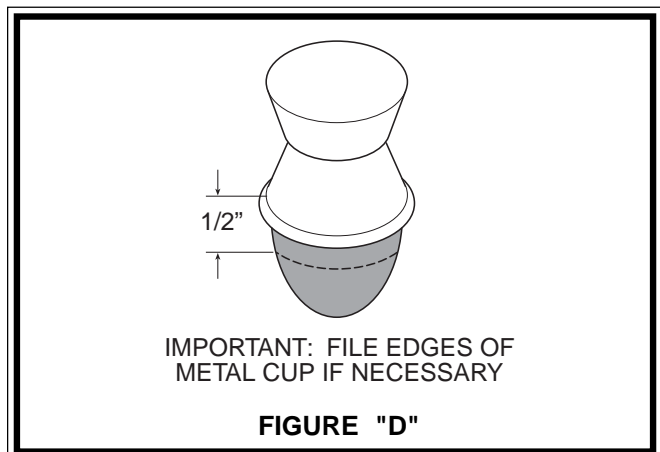

FIGURE "C"



IMPORTANT: FILE EDGES OF METAL CUP IF NECESSARY

FIGURE "D"

PLEASE TAKE ALL NECESSARY SAFETY PRECAUTIONS WHEN INSTALLING YOUR COIL-RITE KIT.

COIL-RITE INSTALLATION PROCEDURE

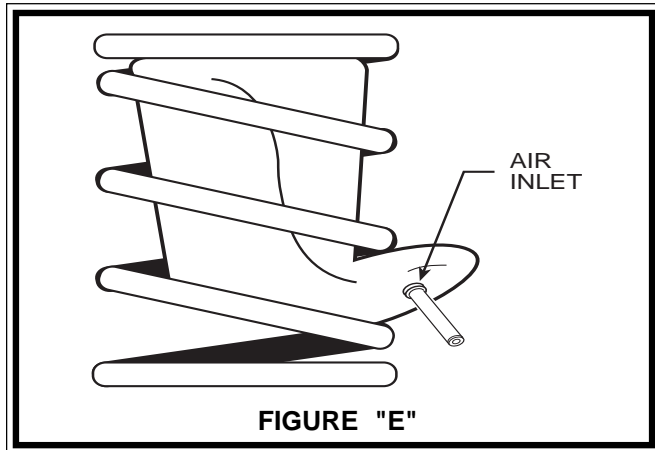

STEP 5 - ADJUST THE AIR SPRING

Push the air spring up into the coil spring by hand or with a blunt tool, such as a spoon shaped tire iron or 1/2" extension. Do NOT use any thing with sharp edges or corners, as this may damage the air spring.

When the air spring is completely within the coil spring, remove the plug and tubing section by pushing the collar on the fitting towards the air spring and pulling on the tubing to remove. Allow the air spring to return to its normal shape. Insert the lower support between the air spring and the lower spring seat *see Figure "F"*.

STEP 6 - RE-ATTACH THE SHOCK ABSORBER

Attach the shock absorber if it was removed earlier in the installation.

REPEAT STEPS 4 THROUGH 6 FOR THE OPPOSITE SIDE OF THE VEHICLE

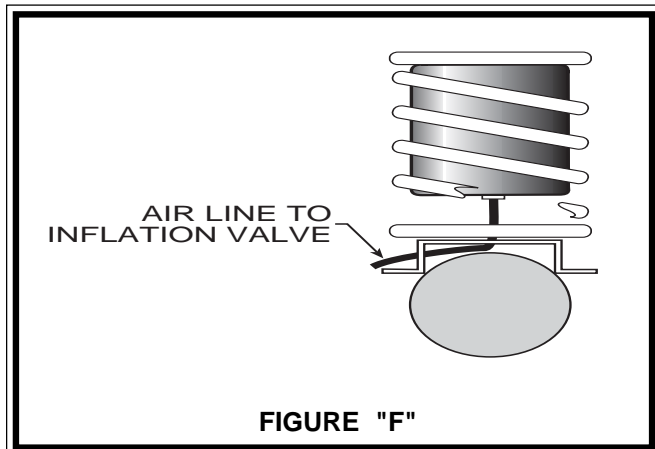

STEP 7 - ROUTE THE AIR LINE

Cut the air line tubing into two equal lengths, making sure the tubing is cut as squarely as possible (a "saw" cut with a sharp knife or razor blade is preferred). Select a location for the inflation valves in a protected area, such as: on the bumper or body (Note: The inflation valve will be installed in step 8).

Insert the air line tubing into the push-to-connect fitting on the air spring as far as possible. Route the air line from the air spring to the desired inflation valve location.

With the tubing routed from the air spring to the location of the inflation valve use the nylon ties supplied to secure the air line tubing to the vehicle as shown in *Figure "G"*. Be careful to avoid areas of high heat and sharp edges when fastening the tubing to the vehicle.

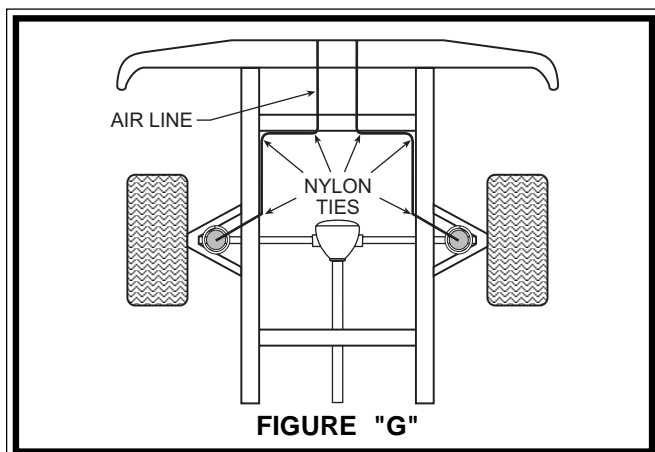

STEP 8 - INSTALL THE INFLATION VALVE

Drill a 5/16" hole where you wish to mount the inflation valve. Remember to keep the inflation valve in a protected area that is easily accessible. Attach the inflation valve to the bumper or body of the vehicle as shown in *Figure "H"*. Tighten all nuts at this time.

Cut the excess air line tubing so that it will fit easily into the inflation valve, making sure the end is cut squarely (a "saw" cut with a sharp knife is preferred). Push the end of the tubing into the inflation valve as far as possible.

NOTE: CHECK AIR PRESSURE ON A MONTHLY BASIS.

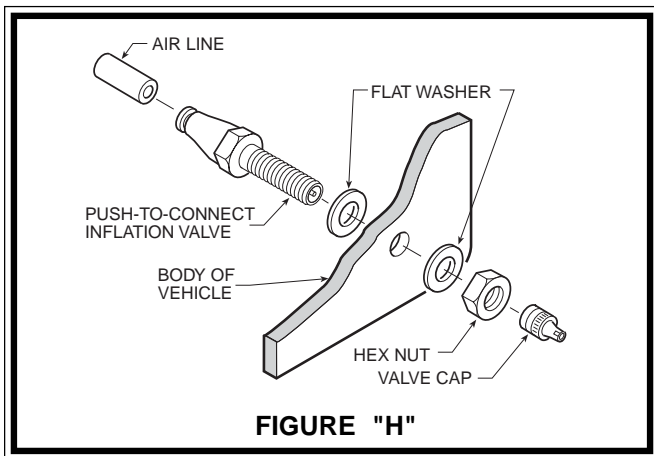

STEP 9 - INFLATE AND TEST

Inflate the air springs to recommended maximum operating pressure (see page 1 for operating pressures). With a soap and water solution, check for air leaks around the fittings and valve core. We recommend inflating and deflating in small increments to find the ideal riding condition for your vehicle.

STEP 10 - COMPLETION

Installation is now complete. Replace the wheels and torque the lug nuts to the manufacturer's specification. Raise the vehicle and remove the jack stands and lower the vehicle to the ground. Re-attach the positive battery cable.

LIMITED WARRANTY FOR COIL-RITE AIR HELPER SPRINGS AND ACCESSORIES

Firestone Industrial Products Company warrants that Coil-Rite products will be free from defects in workmanship or materials for a period of 24 months or 24,000 miles (whichever occurs first) from date of installation. This does not include installation or other service charges for replacement.

For an adjustment under this warranty, contact your dealer or call Firestone.

TO THE EXTENT PERMITTED BY LAW, WE DISCLAIM CONSEQUENTIAL DAMAGES. SOME STATES DO NOT ALLOW THE EXCLUSION OR LIMITATION OF INCIDENTAL OR CONSEQUENTIAL DAMAGES, SO THE ABOVE LIMITATION OR EXCLUSION MAY NOT APPLY TO YOU.

This warranty gives you specific legal rights and you may also have other rights which vary from state to state.

*FOR MORE INFORMATION OR TECHNICAL
ASSISTANCE CALL:
1-800-247-4337*

FIRESTONE INDUSTRIAL PRODUCTS
12650 HAMILTON CROSSING BOULEVARD
CARMEL, IN 46032
FAX: 317-818-8645
www.ride-rite.com

Firestone
RIDE-RITE® - COIL-RITE® - SPORT-RITE™
World's Number 1 Air Spring